

# GENERAL PURPOSE THERMAL MASS FLOWMETER MODEL 4140/4143

---

OPERATION AND SERVICE MANUAL

P/N 1980383, REVISION G  
FEBRUARY 2016



# START SEEING THE BENEFITS OF REGISTERING TODAY!

---

Thank you for your TSI instrument purchase. Occasionally, TSI releases information on software updates, product enhancements and new products. By registering your instrument, TSI will be able to send this important information to you.

As part of the registration process, you will be asked for your comments on TSI products and services. TSI's customer feedback program gives customers like you a way to tell us how we are doing.



UNDERSTANDING, ACCELERATED

©2015 TSI Incorporated

Printed in U.S.A.

# GENERAL PURPOSE THERMAL MASS FLOWMETER MODEL 4140/4143

OPERATION AND SERVICE MANUAL

P/N 1980383, REVISION G  
FEBRUARY 2016





	<b>WARNING</b>
	TSI flowmeters employ a heated platinum sensor. They should not be used with flammable or explosive gasses or mixtures.

	<b>Caution</b>
	TSI flowmeters are not medical devices under FDA 510k and in no situation should they be utilized for human respiration measurements.

**LIMITATION OF WARRANTY AND LIABILITY** (effective February 2015)

Seller warrants the goods, excluding software, sold hereunder, under normal use and service as described in the operator's manual, to be free from defects in workmanship and material for **12 months**, or if less, the length of time specified in the operator's manual, from the date of shipment to the customer. This warranty period is inclusive of any statutory warranty. **This limited warranty is subject to the following exclusions and exceptions:**

- a. Hot-wire or hot-film sensors used with research anemometers, and certain other components when indicated in specifications, are warranted for 90 days from the date of shipment;
- b. Pumps are warranted for hours of operation as set forth in product or operator's manuals;
- c. Parts repaired or replaced as a result of repair services are warranted to be free from defects in workmanship and material, under normal use, for 90 days from the date of shipment;
- d. Seller does not provide any warranty on finished goods manufactured by others or on any fuses, batteries or other consumable materials. Only the original manufacturer's warranty applies;
- e. This warranty does not cover calibration requirements, and seller warrants only that the instrument or product is properly calibrated at the time of its manufacture. Instruments returned for calibration are not covered by this warranty;
- f. This warranty is **VOID** if the instrument is opened by anyone other than a factory authorized service center with the one exception where requirements set forth in the manual allow an operator to replace consumables or perform recommended cleaning;
- g. This warranty is **VOID** if the product has been misused, neglected, subjected to accidental or intentional damage, or is not properly installed, maintained, or cleaned according to the requirements of the manual. Unless specifically authorized in a separate writing by Seller, Seller makes no warranty with respect to, and shall have no liability in connection with, goods which are incorporated into other products or equipment, or which are modified by any person other than Seller.

The foregoing is **IN LIEU OF** all other warranties and is subject to the **LIMITATIONS** stated herein. **NO OTHER EXPRESS OR IMPLIED WARRANTY OF FITNESS FOR PARTICULAR PURPOSE OR MERCHANTABILITY IS MADE. WITH RESPECT TO SELLER'S BREACH OF THE IMPLIED WARRANTY AGAINST INFRINGEMENT, SAID WARRANTY IS LIMITED TO CLAIMS OF DIRECT INFRINGEMENT AND**

**EXCLUDES CLAIMS OF CONTRIBUTORY OR INDUCED INFRINGEMENTS. BUYER'S EXCLUSIVE REMEDY SHALL BE THE RETURN OF THE PURCHASE PRICE DISCOUNTED FOR REASONABLE WEAR AND TEAR OR AT SELLER'S OPTION REPLACEMENT OF THE GOODS WITH NON-INFRINGEMENTS.**

TO THE EXTENT PERMITTED BY LAW, THE EXCLUSIVE REMEDY OF THE USER OR BUYER, AND THE LIMIT OF SELLER'S LIABILITY FOR ANY AND ALL LOSSES, INJURIES, OR DAMAGES CONCERNING THE GOODS (INCLUDING CLAIMS BASED ON CONTRACT, NEGLIGENCE, TORT, STRICT LIABILITY OR OTHERWISE) SHALL BE THE RETURN OF GOODS TO SELLER AND THE REFUND OF THE PURCHASE PRICE, OR, AT THE OPTION OF SELLER, THE REPAIR OR REPLACEMENT OF THE GOODS. IN THE CASE OF SOFTWARE, SELLER WILL REPAIR OR REPLACE DEFECTIVE SOFTWARE OR IF UNABLE TO DO SO, WILL REFUND THE PURCHASE PRICE OF THE SOFTWARE. **IN NO EVENT SHALL SELLER BE LIABLE FOR LOST PROFITS, BUSINESS INTERRUPTION, OR ANY SPECIAL, INDIRECT, CONSEQUENTIAL OR INCIDENTAL DAMAGES.** SELLER SHALL NOT BE RESPONSIBLE FOR INSTALLATION, DISMANTLING OR REINSTALLATION COSTS OR CHARGES. No Action, regardless of form, may be brought against Seller more than 12 months after a cause of action has accrued. The goods returned under warranty to Seller's factory shall be at Buyer's risk of loss, and will be returned, if at all, at Seller's risk of loss.

Buyer and all users are deemed to have accepted this LIMITATION OF WARRANTY AND LIABILITY, which contains the complete and exclusive limited warranty of Seller. This LIMITATION OF WARRANTY AND LIABILITY may not be amended, modified or its terms waived, except by writing signed by an Officer of Seller.

**Service Policy**

Knowing that inoperative or defective instruments are as detrimental to TSI attention to any problems. If any malfunction is discovered, please contact your nearest sales office or

# CONTENTS

## CHAPTERS

<b>1 UNPACKING AND PARTS IDENTIFICATION.....</b>	<b>1</b>
<b>2 SETTING-UP.....</b>	<b>3</b>
Supplying Power.....	3
Connecting Filter and Flow Tubes.....	4
RS232 Configuration and Operation.....	4
Configuration Software.....	5
<b>3 OPERATION.....</b>	<b>7</b>
Overview.....	7
ON/OFF Switch.....	7
Warm-up Time.....	7
Flow Rate Measurement.....	7
Pressure Measurement.....	8
Select Measurement Displayed.....	8
Display “Scroll” Mode.....	8
Volume Measurement.....	8
<b>4 MAINTENANCE.....</b>	<b>9</b>
Flow Sensor.....	9
Re-certification.....	9
Cases.....	9
Storage.....	9
<b>5 TROUBLESHOOTING.....</b>	<b>11</b>

## APPENDIXES

<b>A SPECIFICATIONS*.....</b>	<b>13</b>
<b>B STANDARD FLOW RATE VS. VOLUMETRIC FLOW RATE...17</b>	

*(This page intentionally left blank)*



# Chapter 1

## Unpacking and Parts Identification

Carefully unpack the instrument and accessories from the shipping container. Check the individual parts against the list of components in Table 1. If any parts are missing or damaged, notify TSI immediately.

Table 1. List of Components

Qty	Item Description	Part/Model
1	Mass Flowmeter, 0.25 inch inlet/outlet (Air, Oxygen, Nitrogen)	4140
	Mass Flowmeter, 0.25 inch inlet/outlet (Air, Oxygen, Nitrogen, Nitrous Oxide)*	41403
	Mass Flowmeter, 0.375 inch inlet/outlet (Air, Oxygen, Nitrogen)	4143
	Mass Flowmeter, 0.375 inch inlet/outlet (Air, Oxygen, Nitrogen, Nitrous Oxide)*	41433
1	Filter Model 4140: 60 mm ULPA filter with 0.25 inch barbed fittings	1602317
	Model 4143: 63 mm HEPA filter with 0.375 inch barbed fittings	1602342
1	AC Adapter 100 to 240 V, N. America NEMA 5-15 plug, grounded	8918-NA
	100 to 240 V, Europlug, CEE 7/16, grounded	8918-EC
	100 to 240 V, Great Britain, grounded, fused	8918-GB
	100 to 240 V, Australia/NZ	8918-AT
1	Operation and Service Manual for Model 4140/4143	1980383
1	RS232 Serial Command Set Manual, 4000/4100	1980340

\*Other than the specifications in [Appendix A](#), all references to 4140 and 4143 in this manual apply to the 41403 and 41433, respectively.

Table 2. Optional Accessories

Item Description	Part/Model
Computer Cable, mini-DIN to 9-pin RS-232	1303583
Analog Cable, mini-DIN to cable with tinned wires	1303584
Carrying Case for Model 4140/4143	1319201

## Parts Identification

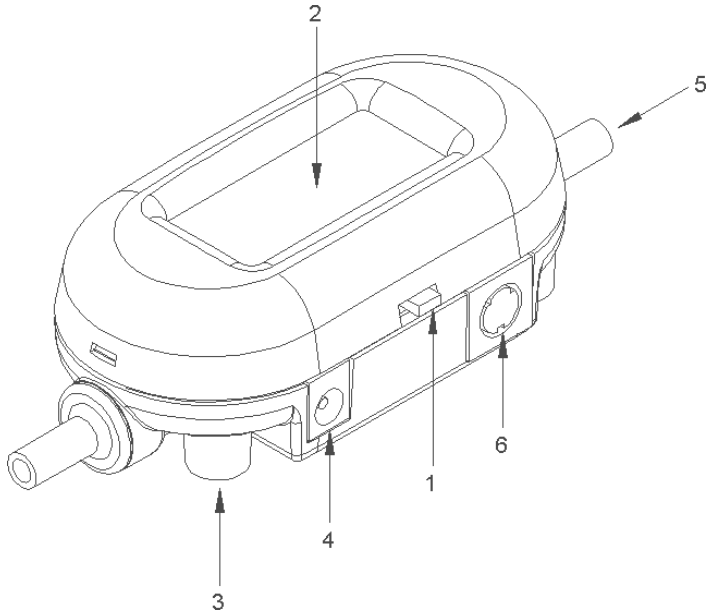

**Figure 1-1 Model 4140/4143 Mass Flowmeter**

- |                         |  |
|-------------------------|--|
| 1. On/Off Switch        | 4. DC Power Input  |
| 2. Display              | 5. Flow Inlet  |
| 3. Mounting Inserts (2) | 6. Computer Serial Interface,<br>Analog Output, and Optional<br>Power Input Connection |

# Chapter 2

## Setting-Up

### Supplying Power

The flowmeter can be powered in one of two ways: through the power jack using the supplied AC adapter or through the mini-DIN connector. The DC power input connector is shown below along with the power requirements.

Power Supply: 7.5 VDC  $\pm$  1.5 V, 300 mA maximum



When supplying power through the optional TSI interface cable, line up the arrow on the connector with the bottom side of the flowmeter. Flowmeter connector pin-out designations are shown below.

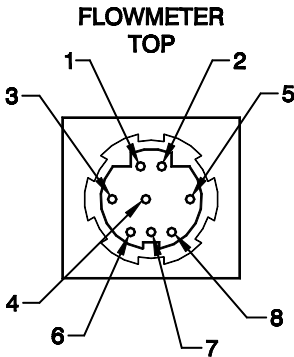

**Table 3. Connector Pin-out and Color Code for TSI Cable PN 1303584**

Pin	Function	Cable Color Code
1	Power Input (+)	Black
2	Power Ground (-)	Green
3	Analog Output (+)	Red
4	Analog Ground (-)	Brown
5	(no connection)	Blue
6	RS232 Receive (in)	White
7	RS232 Transmit (out)	Yellow
8	Logic Ground	Gray

## Connecting Filter and Flow Tubes

The Model 4140/4143 has a thermal sensor exposed to the gas flow that must be protected from foreign matter and particles. TSI supplies a filter that should be connected to the inlet of the flowmeter, however, any filter will work as long as it has a minimum efficiency of 99.9%.

	<b>CAUTION</b>
	Always use a filter on the inlet of the flowmeter. Failure to filter the gas flow may change the calibration and/or permanently damage the sensor.

---

**Note:** Flow direction is identified by the large arrow printed on the bottom side of the flowmeter.

---

After attaching the filter connect the flow tube to the inlet of the filter. Connecting a tube to the outlet of the flowmeter will create back pressure. See [Appendix A](#) for flowmeter accuracy specifications when operating at various pressures. In general, minimize back pressure on the flowmeter to maintain higher accuracy.

## RS232 Configuration and Operation

Many flowmeter operating parameters can be easily configured through the RS232 serial port. Likewise, the flow rate, temperature, pressure, and volume can be read through the serial port. Refer to the **Series 4000/4100 RS232 Serial Command Set** manual for a detailed description of the commands and command syntax.

**RS232 Settings:**

- Baud Rate..... 38.4 k
- Data Bits ..... 8
- Parity..... None
- Stop Bits ..... 1
- Flow Control..... None

**Table 4. Changeable Operating Parameters**

Function	Command
Select Gas Calibration air, O <sub>2</sub> , N <sub>2</sub> , or N <sub>2</sub> O(if available)	SGn
Select Standard or Volumetric Flow Measurement	SUn
LCD Display Update Rate (controls averaging)	SURnnnn
Select Measurement Display Scroll Mode	SDMFTPn
Select Measurement Displayed on LCD Display	SDMm
Select Measurement Units on LCD Display	SDUn
Select Data Update Rate for Analog Output	SSRnnnn
Set Analog Output Full-Scale Flow Rate Value	SASnnn
Set Analog Output Zero Value	SAZnnn

### Configuration Software

TSI has several software utilities to help you communicate with your flowmeter to change parameters and to obtain flow data. You can download the latest versions of these at no charge from our web site:

1. If you only want to change one or more of the operating parameters shown in Table 4 (above), the easiest way is to use the software utility called **“TSI setup.”** This uses convenient drop-down menus to help change these parameters. After you have made your changes, be sure to click on **“Send”** to store the changes in the flowmeter’s memory.

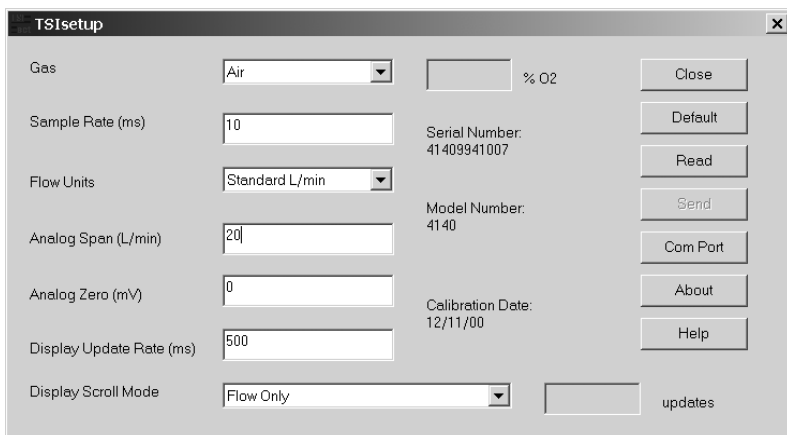

2. If you want to communicate directly with the flowmeter using the basic RS232 commands shown in the ***Serial Command Set Manual***, you can use a terminal program. HyperTerminal is a common terminal program that is included with most versions of the Microsoft operating system. Setting up HyperTerminal to communicate with your flowmeter can sometimes be confusing. You can download a document from our web site that helps you configure HyperTerminal. Download the document called ***“Using HyperTerminal to communicate with TSI Flowmeters.”***
3. If you plan to develop a more sophisticated program for data collection and control using LabVIEW, you can download a demonstration program called ***“Real-time Demo Program”*** and the source code ***“Source Code for Real-time Demo Program.”*** This program is intended to be a basic demonstration program and not a practical laboratory tool. It does, however, have a convenient implementation of the VOLUME measurement function that can be useful for basic tests.

# Chapter 3

## Operation

---

	<b>CAUTION</b>
	TSI flowmeters are not medical devices under FDA 510k and in no situation should they be utilized for human respiration measurements.

### Overview

The Model 4140/4143 Flowmeter measures mass flow rate, temperature and absolute pressure of the gas inside the flow tube. All measurements made by the Models 4140/4143 are NIST traceable.

### ON/OFF Switch

Slide the switch to the ON position. The power switch is marked in the international symbols 'I' for *on* and 'O' for *off*.

### Warm-up Time

The flowmeter will provide readings immediately upon power-up. Recommended warm-up time of the flowmeter is 5 minutes.

### Flow Rate Measurement

Flow rate data can be obtained from the Model 4140/4143 through the LCD display, RS232 serial port, or the linearized analog output. The analog output is a 0 to 10 volt DC linear signal representing 0 to 20 Std L/min. The analog output scaling is user selectable. Refer to the **Series 4000/4100 RS232 Serial Command Set** manual for instructions on how to obtain flow data through the serial port.

Gas calibrations (air, 100% O<sub>2</sub>, 100% N<sub>2</sub> or 100% N<sub>2</sub>O) can be selected through the RS232 serial port. Refer to the **Series 4000/4100 RS232 Serial Command Set** manual. The LCD display will indicate the calibration being utilized: air, O<sub>2</sub>, N<sub>2</sub>, or N<sub>2</sub>O.

Flow can be displayed in units of standard liters per minute (Std L/min<sup>\*</sup>) or in volumetric units of liters per minute (L/min). Refer to [Appendix B](#) for a description of the two measurements. Selecting between the two measurements is accomplished through the serial

---

<sup>\*</sup>TSI instruments defines standard conditions as 21.1°C (70° F) and 101.3 kPa (14.7 psia, 1 bar).

port. Refer to the **Series 4000/4100 RS232 Serial Command Set** manual for instructions on how to select between flow units.

The Model 4140/4143 has an independent temperature sensor in the flow tube to measure the gas temperature. The temperature sensor is used for temperature compensation of flow rate and for converting flow from standard to volumetric units. Temperature can also be displayed on the LCD and is available through the RS232 serial port in the units of degrees Celsius (°C).

---

**Note:** At low flow rates, the temperature inside of the flow tube will increase because of the heat generated by the thermal flow sensor. This effect is normal and the temperature of the incoming gas will be measured once flow resumes.

---

### **Pressure Measurement**

The Models 4140/4143 measure absolute pressure near the outlet of the flowmeter in the SI units of kilo-Pascals (kPa). Pressure measurements are required when converting from standard to volumetric flow. Absolute pressure can be displayed on the LCD and is available through the RS232 serial port.

### **Select Measurement Displayed**

By using RS232 commands the LCD display can be set up to continuously display either flow rate, temperature, or pressure. See the **SDMm** command in the **Series 4000/4100 Serial Command Set** manual.

### **Display “Scroll” Mode**

By using RS232 commands the LCD display can be set up to continuously scroll between flow rate, temperature, and pressure. The scroll rate is adjustable and the user can specify the parameters to be displayed. See the **SDMFTPn** command in the **Series 4000/4100 Serial Command Set** manual.

### **Volume Measurement**

These flowmeters measure total volume by integrating flow over time. This is a calculated measurement performed by the flowmeter and is only available using the RS232 serial port. Volume is not displayed on the LCD display. Refer to the **Series 4000/4100 RS232 Serial Command Set** manual for instructions on using the volume function.



# Chapter 4

## Maintenance

---

### Flow Sensor

Periodically inspect the flow sensor by looking into the outlet of the flowmeter. Remove dust, particles and fibers from the sensor with clean, dry compressed air. The flow sensor will break if touched.

**Never run liquids through the flowmeter and never touch the sensor with a brush.** Dust or other deposits on the flow sensor will degrade the 4140/4143 flowmeter's flow accuracy.

	<b>CAUTION</b>
	The flowmeter must be switched off for cleaning. Only use clean, dry, compressed air when attempting to remove contamination from the sensor.

### Re-certification

To maintain a high degree of confidence in the measurements made by the Model 4140/4143, TSI recommends that the instrument be returned to TSI every 12 months for re-certification. The flowmeter will be recalibrated and returned with a certificate of calibration to US National Institute of Standards Technology (NIST) traceable standards. This “annual checkup” assures you of consistently accurate readings; it is especially important in applications where strict calibration records must be maintained.

### Cases

If the instrument case or storage case needs cleaning, wipe it off with a soft cloth dipped in isopropyl alcohol or mild detergent. **Never** submerge the flowmeter or allow liquids to enter the flow tube.

### Storage

When storing the flowmeter, always cover the ends of flow tubes with the caps provided to prevent dust or other foreign matter from entering the tube.

*(This page intentionally left blank)*

# Chapter 5

## Troubleshooting

---

Table 4 lists the symptoms, possible causes, and recommended solutions for common problems encountered with Series 4100 flowmeters. If the symptom is not listed, or if none of the solutions

**Table 4. Troubleshooting**

Symptom	Possible Causes	Corrective Action
No display.	Unit not switched on.	Switch on the unit.
	No power to instrument.	Plug in AC adapter or check power source on mini-DIN connector.
Temperature reads high at low or zero flows.	Temperature sensor is being heated from the flow sensor.	The temperature value will track the actual gas temperature once the flow rate through the flowmeter exceeds 1 Std L/min.
Flow readings fluctuate greatly.	The flow is fluctuating.	Improve inlet conditions or increase display averaging time.
Display shows flows over-range with no flow passing through flow tube.	The sensor may be damaged or broken.	Return flowmeter to TSI for service.

*(This page intentionally left blank)*

# Appendix A

## Specifications\*

<b>Flow Measurement</b>	
Measurement Range .....	0.01 to 20 Std L/min.
Accuracy	
Air and 100% O <sub>2</sub> .....	2% of reading or .005 Std L/min, whichever is greater,
100% N <sub>2</sub> .....	3% of reading or .010 Std L/min, whichever is greater,
100% N <sub>2</sub> O .....	3% of reading or .010 Std L/min, whichever is greater,
(41403 and 41433 only)	Accuracy stated at standard conditions (21.1°C and 101.3 kPa)
	See notes <b>1</b> through <b>6</b> below.
Resolution (Display).....	0.001 Std L/min between 0.01 and 9 Std L/min 0.01 Std L/min between 9 and 20 Std L/min
Response.....	Less than 4 msec, 63% of final value at full scale flow
<b>Temperature Measurement</b>	
Measurement Range .....	0 to 50°C
Accuracy.....	±1°C, at flows greater than 1 L/min. See note <b>2</b> below.
Resolution (Display).....	0.1°C
Response.....	Less than 75 msec, 63% of final value for 20°C step change in temperature at full scale flow
<b>Static Pressure Measurement (Measured inside flow tube near the exit)</b>	
Measurement Range .....	50 to 199 kPa Absolute
Accuracy.....	±1 kPa, See note <b>7</b> below.
Resolution (Display).....	0.1 kPa
Response.....	Less than 4 msec.
	63% of final value for 30 kPa step change
Over Pressure.....	620 kPa
<b>Burst Pressure</b>	
Tested to 690 kPa without rupture. Do <b>not</b> exceed 690 kPa.	
<b>Pressure Drop</b>	
See Chart.	

<b>Volume</b>	
Measurement Range .....	0.001 to 99.99 Liters
Accuracy	
Air and 100% O <sub>2</sub> .....	2% of Reading at flows greater than 2.5 Std L/min
100% N <sub>2</sub> .....	3% of Reading at flows greater than 2.5 Std L/min
100% N <sub>2</sub> O .....	3% of Reading at flows greater than 2.5 Std L/min
(41403 and 41433 only)	See notes <b>1</b> through <b>5</b> below.
<b>Instrument Temp. Range</b>	
Operation, Ambient.....	0 to 50°C
Storage, Ambient.....	-20 to 60°C
<b>Gas Calibrations</b>	
Air, O <sub>2</sub> , N <sub>2</sub> , N <sub>2</sub> O (41403 and 41433 only), User selectable through serial port	
<b>Physical Dimensions</b>	
External Dimensions.....	See Diagram
Tube Adapters .....	Model 4140/41403: 0.25 inch O.D. straight (Inlet & Outlet) Model 4143/41433: 0.375 inch O.D. straight
Weight .....	86 grams
Flow Body Material .....	Polycarbonate
<b>Computer Interface</b>	
Connector .....	8 pin mini-DIN
Type .....	RS232 Serial
Baud Rate .....	38,400
Data Bits .....	8
Parity .....	None
Stop Bits .....	1
Flow Control .....	None
<b>Analog Output (Flow Only)</b>	
Range.....	0 to 10 V
Resolution .....	13 bit
Maximum Current .....	5 ma
Flow Accuracy .....	See note <b>6</b> below.
<b>Power</b>	
AC adapter or power supplied through mini-DIN 7.5 VDC ± 1.5 V, 300 mA maximum	

**Notes:**

- 1 Accuracy stated at standard conditions of 21.1°C and 101.3 kPa.
  - Add an additional 0.0003 Std L/min or 0.075% of reading, whichever is greater, per 1°C away from standard conditions when operating within the range of 0°C to 50°C.
  - Add an additional 0.015% of reading per 1 kPa above 101.3 kPa or
  - Add an additional 0.022% of reading per 1 kPa below 101.3 kPa when operating within the pressure range of 70 kPa to 101.3 kPa.
- 2 Accuracy stated with gas temperature and flow body temperature within  $\pm 10^{\circ}\text{C}$  of one another.
- 3 Accuracy stated measuring dry gas (less than 10% R.H.).
- 4 Includes  $\pm 0.5\%$  of reading repeatability.
- 5 Volumetric flow rate is calculated from the mass flow measurement. Add an additional 0.25% of reading to the flow accuracy to account for the uncertainty in measuring gas temperature and pressure.
- 6 For analog output, accuracy offset increases from 0.005 to .02 Std L/min.
- 7 Add uncertainty of 0.2 kPa for every 10°C away from 21.1°C.

*\*Specifications subject to change without notice.*

*(continued on next page)*

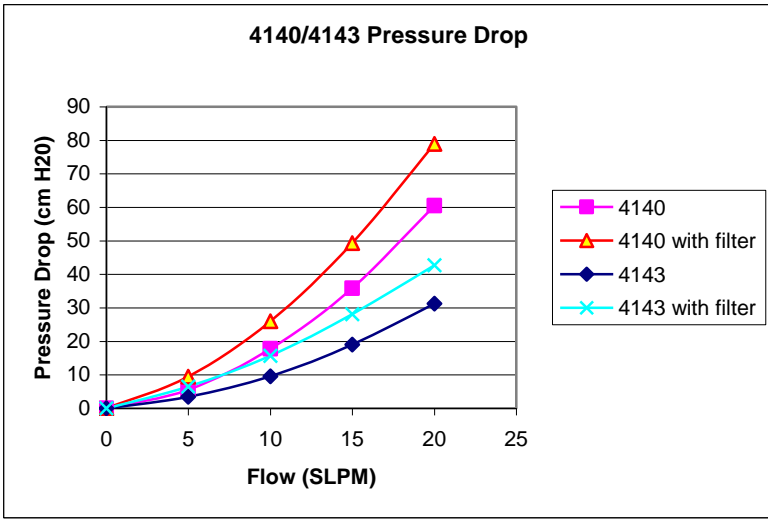

**Figure A-1 Pressure Drop**

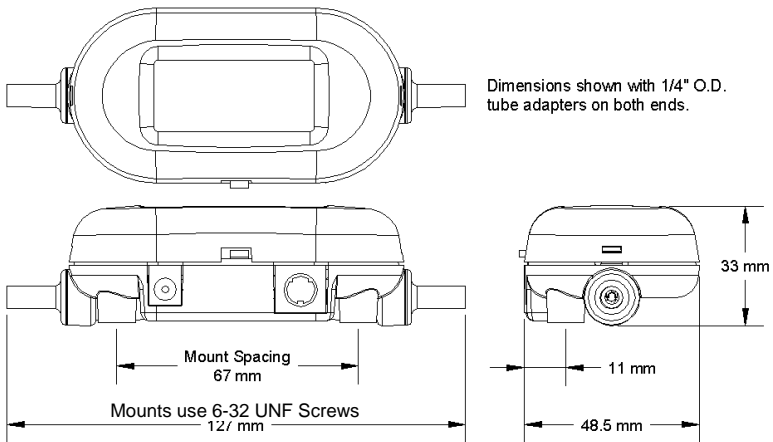

**Figure A-2 Model 4140/4143 Dimensions**



## Appendix B

### Standard Flow Rate vs. Volumetric Flow Rate

---

Since thermal flow sensors are sensitive to changes in air density and air velocity, all thermal flowmeters indicate flow rates with reference to a set of standard conditions. For TSI instruments, standard conditions are defined as 21.1° C (70° F) and 101.3 kPa (14.7 psia). Other manufacturers may use different values.

Standard flow rate is the flow rate the air would be moving if the temperature and pressure were at standard conditions. It is usually the most useful measure of airflow because it defines the heat-carrying capacity of the air.

Volumetric flow rate is the true volume flow of the gas exiting the flowmeter.

In some instances, volumetric flow rate rather than standard flow rate may be of interest. To display volumetric flow rate, the Model 4140/4143 will multiply the standard flow measurement by the following density correction factor:

$$\text{Volumetric Flow} = (\text{Standard Flow}) \left[ \frac{273.15 + T_m}{273.15 + 21.11} \right] \frac{101.3}{P_m}$$

Where

$T_m$  = Gas temperature measured in flow tube in units of degrees Celsius

$P_m$  = Absolute pressure measured in flow tube in units of kPa

To demonstrate the difference in output, consider the following.

Measured flow displays 10 Std L/min at 15C and 117kPa. The volumetric flow as calculated by the Model 4140/4143 would be as follows.

$$\text{Volumetric Flow} = (10) \left[ \frac{273.15 + 15}{273.15 + 21.11} \right] \frac{101.3}{117} = 8.478 \text{ L / min}$$



UNDERSTANDING, ACCELERATED

P/N 1980383 Rev G

Copyright © 2016 by TSI Incorporated

Printed in U.S.A.



Quality Products Online at:

[www.GlobalTestSupply.com](http://www.GlobalTestSupply.com)

[sales@GlobalTestSupply.com](mailto:sales@GlobalTestSupply.com)