

FlexSmart™ Analog Module

(Part No: S-FS-CVIA)



Quick Start Guide

Inside this package:

- FlexSmart Analog Module
- Detachable screw terminal connector
- Imprintable label
- This guide

© 2009–2010 Onset Computer Corporation
Manual Part No: MAN-S-FS-CVIA
Doc No: 10092-E

Note: Refer to the documentation provided with the Onset HOBO® Energy Logger and HOBOWare® Pro software for additional information on using and configuring the FlexSmart Analog Module.

Introduction

Thank you for purchasing an Onset FlexSmart Analog Module. With proper care, it will give you years of accurate and reliable measurements.

The FlexSmart Analog module is an easy-to-configure, flexible DC signal-conditioning module for the Onset H22-001 HOBO Energy Logger. This two-channel module can accept (and provide excitation power to) a wide range of Onset and third-party sensors/transducers with 0-20V or 0-20mA output, including devices with 4-20mA current loop interface, and sensors/transducers with 0-2.5, 0-5, and 0-10 V DC output.

The module features input protection and signal filtering, as well as delta-sigma A/D conversion and factory calibration.

The module also features extremely low-power operation, resulting in long battery life for unattended data logging applications.

Specifications

Input Channels	Two, single-ended
Field Wiring	Two- or three-wire via screw terminals on detachable connector, 16-24 AWG Replacement detachable connectors: Part of spares kit, Onset part no: A-FS-CVIA-7P-1
Input Range	User-configurable: 0-20 mA DC, 0-20 VDC (suitable for 2.5, 5, 10V sensors)
Minimum / Maximum Input Voltage	0 / 24 VDC
Minimum / Maximum Input Current	0 / 24 mADC
Minimum Current Source Impedance	> 20 K Ω
Accuracy	+/- 0.25% of FSR from 50mV to FSV
ADC Resolution	12 bits
Power Requirements	+3.3V @ 3mA active, 6 μ A sleep
Sensor/Transducer Excitation Power	12 VDC @ 200mA max.
CE	The CE Marking identifies this product as complying with all relevant directives in the European Union (EU).

Module Connections

Sensors/transducers are connected to the module via a seven-pin Phoenix-style detachable screw terminal connector. Once the sensors/transducers are connected, the module can then be configured using HOBOWare Pro software (with the module installed on the HOBO Energy Logger).

The diagram below illustrates *typical* connections for a transducer with DC voltage output (requiring no excitation) and a transducer with DC current output (requiring excitation). For module connection instructions specific to sensors/transducers purchased from Onset, refer to the documentation provided with each sensor/transducer.

NOTES:

- Each channel of the module is individually configurable. Collected data can be scaled to produce meaningful engineering units that are consistent with the properties being measured.
- The module is a single-ended device. Pins 3 and 7 are connected to signal ground and to each other.

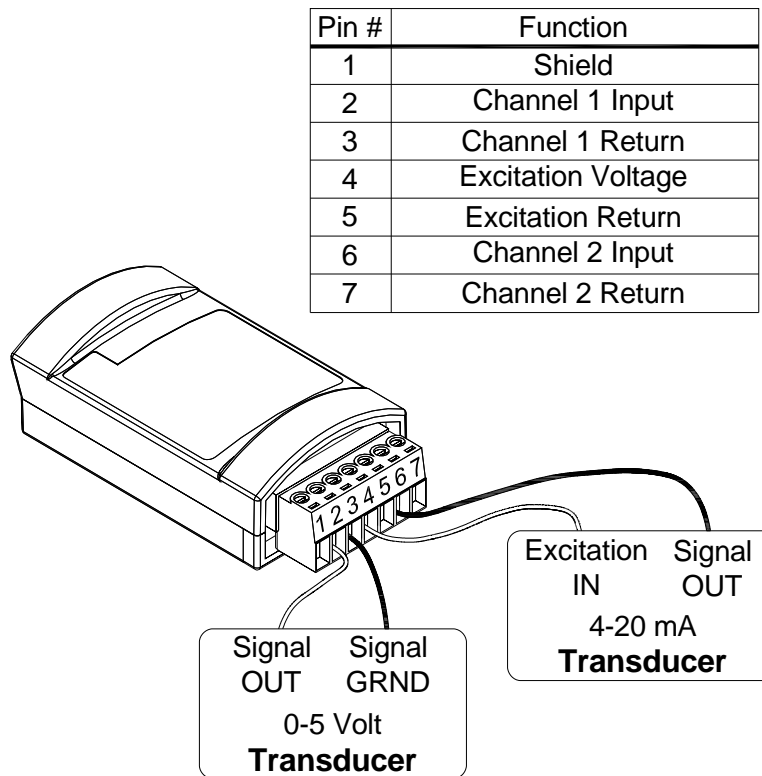

© 2009–2010 Onset Computer Corporation. All rights reserved.

Onset, HOBOWare, and HOBOWare are registered trademarks and FlexSmart are trademarks of Onset Computer Corporation. Other products and brand names may be trademarks or registered trademarks of their respective owners.