

Operation Manual



Warning

Do not attempt to repair or alter this instrument. Warranty will be voided and damage to the unit may result.

Use and store within the stated temperature and humidity ranges, or damage and failure may result.

Ensure during testing unit is properly used on a stable, level surface.

Do not test products that are filled with liquid as the TNP torque tester is not protected from liquid spills.

Only use electrical charger supplied with unit.

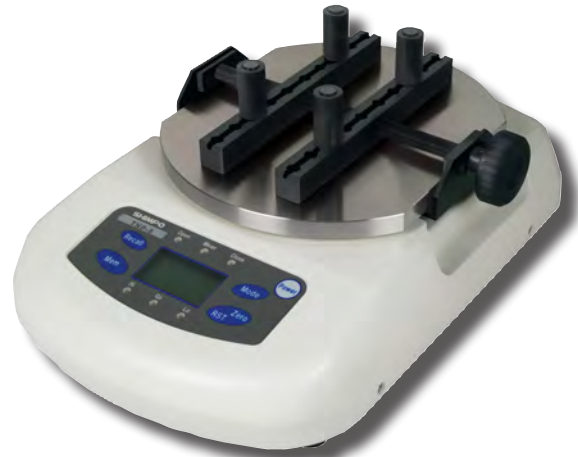

The Series TNP Digital Torque Meter is a precision instrument for measuring OPEN and CLOSE torque values for various applications. The TNP Torque Meter is used in medical, pharmaceutical, industrial quality control, R&D and countless other torque applications.

As a cap torque analyzer, the TNP repeatedly determines bottle closure and breakaway torque. Its wide memory capacity is capable of storing 1,000 data points, including Average, Maximum and Minimum values. A HI-GO-LO LED comparator feature can be utilized for large batch testing to ensure overall product quality. The TNP is a portable device powered with internal rechargeable batteries or through provided universal AC adapter/charger.

Designed with a small footprint, it can easily be transferred between the shop floor and laboratory taking up little space when operating. The TNP Torque Meter comes standard with USB connection and cable for easy PC/Software interface. Combined with the free "DigiTorq" Software, statistical testing, graphing and analysis can be performed.

Each package includes the following:

- Operations Manual
- Software Installation Disk (DigiTorq Software)
- Warranty Card
- USB A to USB B communication cable
- Universal AC adapter (100-240 VAC)
- Set of 30 mm chuck pins (4 pieces)
- TNP unit

SPECIFICATIONS

Measuring Range: **TNP-0.5:** 0-50.00 Ncm, 0-500.0 mNm, 0-5099 gcm, 0-4.425 lbin; **TNP-2:** 0-2.000 Nm, 0-200.0 Ncm, 0-20.39 kgcm, 0-17.70 lbin; **TNP-5:** 0-5.00 Nm, 0-500.0 Ncm, 0-50.99 kgcm, 0-44.25 lbin; **TNP-10:** 0-10.00 Nm, 0-1000 Ncm, 0-102.0 kgcm, 0-88.5 lbin

Test Sample Diameter Range: 0.39" - 7.48" (10 - 190 mm)

Accuracy: ±0.5% / F.S.

Display: Main display: 4-digit LCD display, Character height 0.5" (12 mm)

Comparator Display: HI - GO - LO (green and red LED indicator)

Display Update Time: Select from 0.125 second (8 times/second), 0.25 second (4 times/second), 0.5 second (2 times/second), 1 second (1 time/second). Peak display: 0.125 second

Measuring Mode: Opening Mode: Show max value when opening (peak display) Displays max counterclockwise torque; Closing Mode: Show max value when closing (peak display) Displays max clockwise torque; Average Mode: Real time display (average value display) Displays torque in real time

Overload: 150% of full scale

Sampling Rate: 1000 Hz

Memory: 1000 data (max)

Data Output: USB1.1

Power: Built in nickel hydride battery (NiMH) or Auto-ranging AC adapter (AC100 - 240V)

Battery Information: NiMH: 8 hours use after full charge. 16 hour max. recharge time.

Operating Environment: 32 - 104°F (0 - 40°C)

Dimensions: 12.60" x 8.94" x 4.96" (320 x 227x 126 mm)

Product Weight: TNP-0.5, -2, -5 = Approx. 17.6 lb (8 kg); TNP-10 = 27.5 lb (12.5 kg)

Package Weight: TNP-0.5, -2, -5 = Approx. 19 lb (8.6 kg); TNP-10 = 30.7 lb (13.9 kg)

Software: DigiTorque TNP Free Download from www.shimpoint.com

Included Accessories: USB cable, 120/240 VAC AC adapter, 30mm chuck pin (4pcs)

Certifications: CE

Warranty: 2 year

Parts and Functions

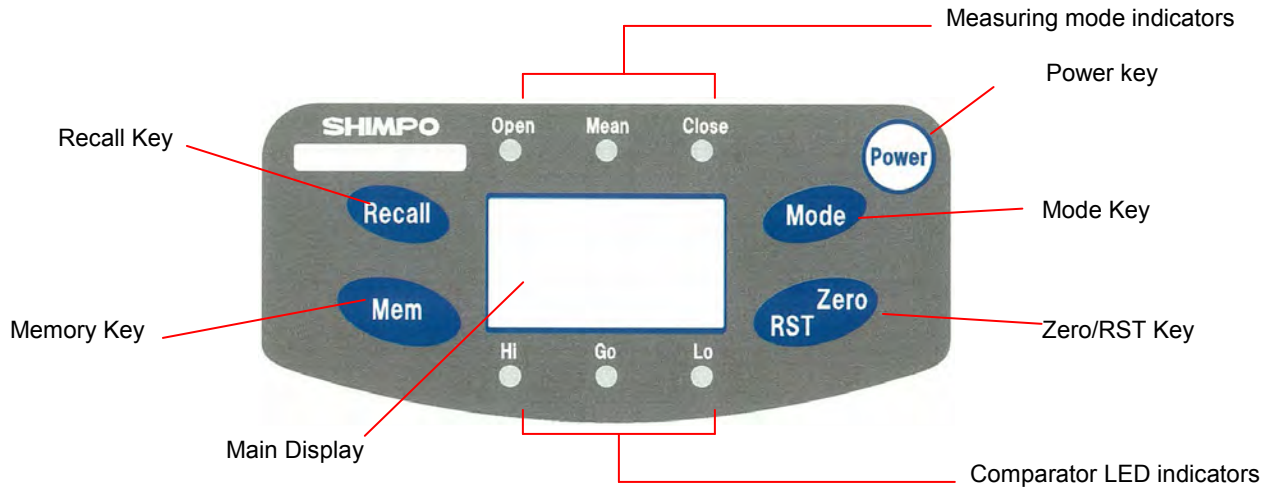

Parts	Functions/Description
Power key	Turns the unit ON and OFF.
Recall key	Recall data stored in OPEN and CLOSE modes. NOTE: in Average or Mean Mode, the Recall button has no function
Mem key	Memory key for storing data in Open and Close Modes. Note: In Mean mode the Mem key has no function. In this mode data cannot be stored in memory. Mem combined with another key is used in secondary functions. (Parameter and clear settings – see next section).
Mode key	Selects mode of operation (CLOSE, MEAN, and OPEN) Serves as an exit function when in Memory recall. Secondary function in parameter settings (see next section)
Zero/RST key	Tare or zero function for resetting and initializing values while in Average or peak mode. Secondary function in parameter settings (see next section)
Main Display	Displays measured values and status indicators, which includes units of measure, battery status and function status.
Measuring mode indicators	Red LED mode indicators. Informs which mode is selected “Open”, “Mean” or “Close”.
Comparator LED Indicators	Quick pass/fail visual indicators for all modes of measurement. The LED indicator does not light when comparator feature is OFF.

Main Display (Description)

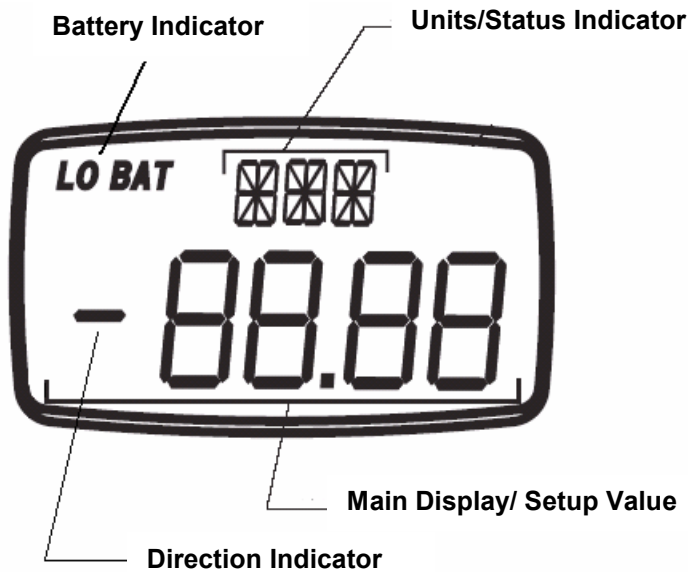

Extended Description

- **Units/Status indicator** – located on the upper part of the display this shows the current units of measure selected for the torque meter. It also serves as a sub display under function mode (F01, F02, F03, etc.)
Example: “OVR” indicates an overload condition the TNP went over its rated capacity. “PWR”, the auto power off feature is set this indicator serves as a 1 minute warning before the unit turns off.

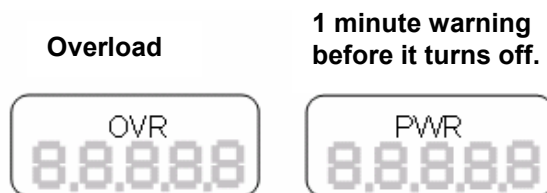

- **Main display/Set up Values** – shows the measured value in four digits including decimal places. While under function mode, this displays the options for each setting.
- **Direction Indicator** – indicates direction of applied torque based from F04 setting (Please see sign orientation information from function mode table). By default, closing indicates a negative “-“values; Opening “no sign”.

- **Battery Indicator** – shows the status of the TNP internal battery. “LO BAT” appears on the display to indicate a low battery status. “**BAT**” is shown when the TNP is charging. This indicator disappears when the battery is fully charged or when the AC adapter is disconnected from the TNP. It is important that the battery be cycled properly to achieve the maximum life from it.

Secondary Functions

Parameter window settings: by using certain key combinations the parameter window can be accessed.

Operation key	Operation	How to operate
Zero/RST Power	Function mode	With Power off, press and hold the Zero/RST key then power ON the torque meter. Continue holding the ZERO/RST key until the display shows “ F01 ”, Pressing MODE changes the value of the selected function mode. Pressing the “ Zero/RST key ” advances from one parameter to the next. The lists of function are provided in the next section. (See picture below for additional description).
Mem Power	Clear memory data	With Power off, press and hold the Mem key , then power ON the torque meter. Continue holding the Mem key until “ nonE ” appears on the display.



This picture indicates the torque meter is in **Function Mode**.



If the display shows the normal operation of the torque meter, and no F01 is seen on the display, the Zero/RST key was released earlier than what is required. Turn off the torque meter and repeat the process.

Function Mode Table

FUNCTION	Sub display	Options	Initial setting
Measuring unit	F01	Changes units of measure TNP-0.5 : mN-m, N-cm, g-cm, lb-in TNP-2, 5, 10 : N-m, N-cm, Kg-cm, lb-in	TNP-0.5 : mN-m TNP-2, 5, 10 : N-m
Display-(update rate)	F02	Switch 1, 2, 4, 8 times/second	2
Auto power OFF	F03	10 minutes or on	10 minutes
Sign Orientation	F04	-0000 CCW (Open "-"); 0000 CCW(Open "+")	0000
Upper comparator value (Hi limit)	HI	0000 – 9999: with decimal point. (Setting the values to zero disables this function) .	0000
Lower comparator value (Lo limit)	LO	0000 – 9999: with decimal point (Setting the values to zero disables this function).	0000

How to change value on the function selected?

To change the values of the function selected, use the Mode key button to scroll through the options and the Zero/RST button to move to the next Mode.



Pressing the Mode button after setting the HI/LO limits exits out of the function mode. You will need to reenter the settings to change additional values.

Operation diagram of how to access the Function Mode

Turn OFF the TNP before starting

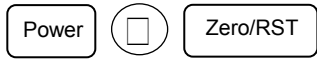

Press and hold the Zero/RST key
Power on then release the Power button
but continue to hold Zero/RST key until display F01

Function Mode – Measurement unit

TNP-2, 5, 10

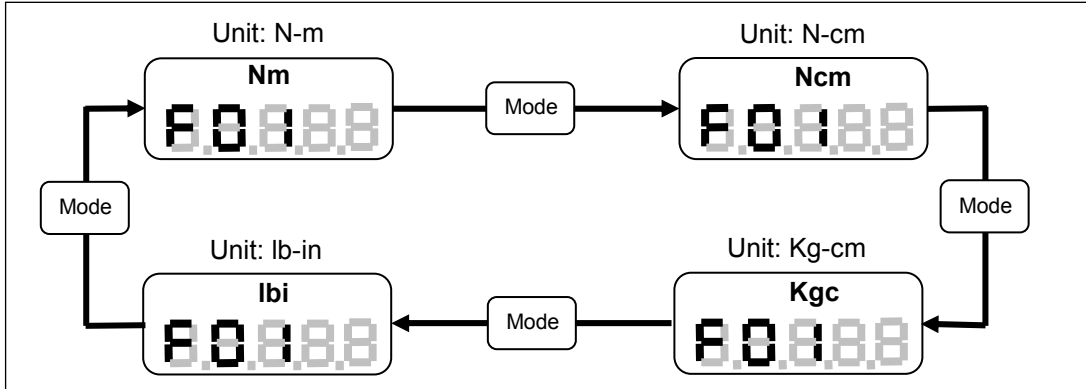

TNP-0.5

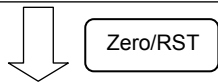
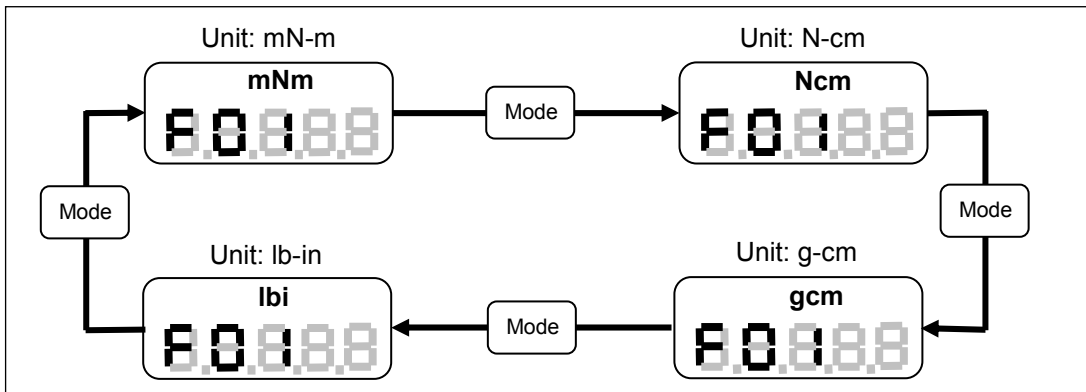

Pressing Zero/RST, it moves to the next function setting.

Use the MODE key to change values of each function.
Use the Zero/RST key for moving to the next function

Function Mode – Display (update rate)

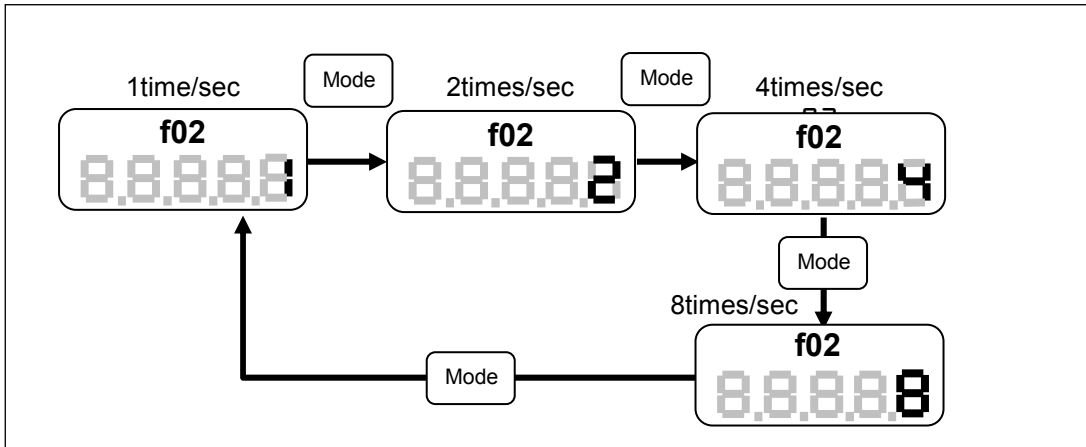

↓ Zero/RST Pressing Zero/RST, it moves to the next function setting.

Function Mode – Auto power OFF

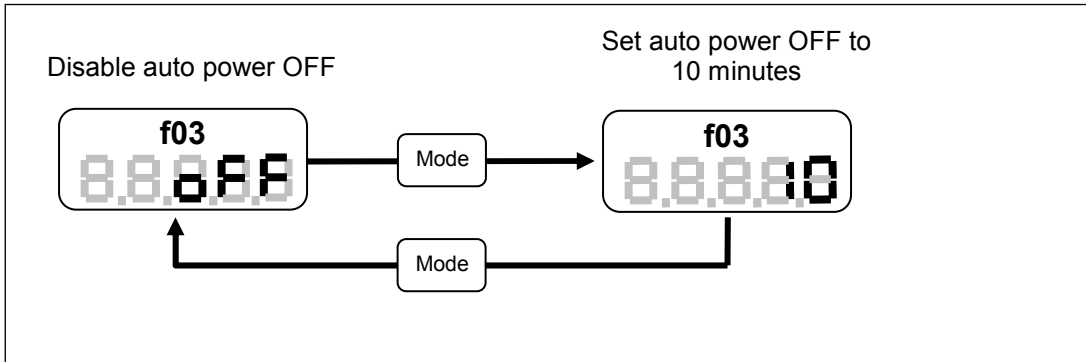

↓ Zero/RST Pressing Zero/RST, it moves to the next function setting.

Function Mode – Sign Orientation

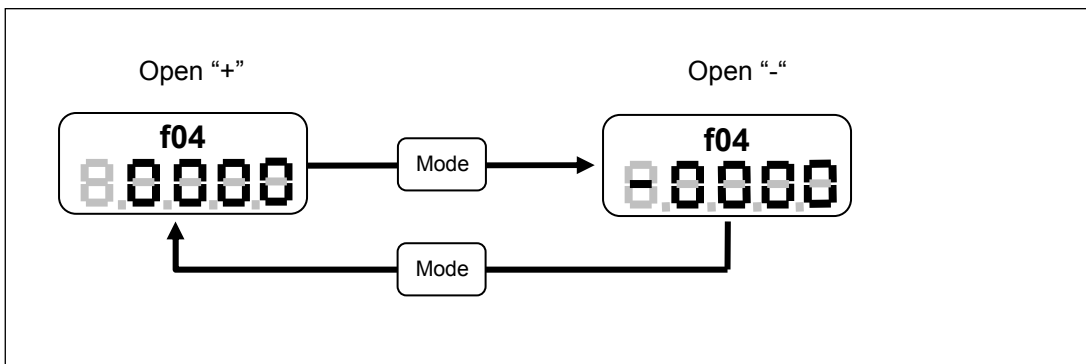

↓ Zero/RST Pressing Zero/RST, it moves to the next function setting.

Use the MODE key to change values of each function.
Use the Zero/RST key for moving to the next function

Function Mode – Upper comparator value (Hi Limit)

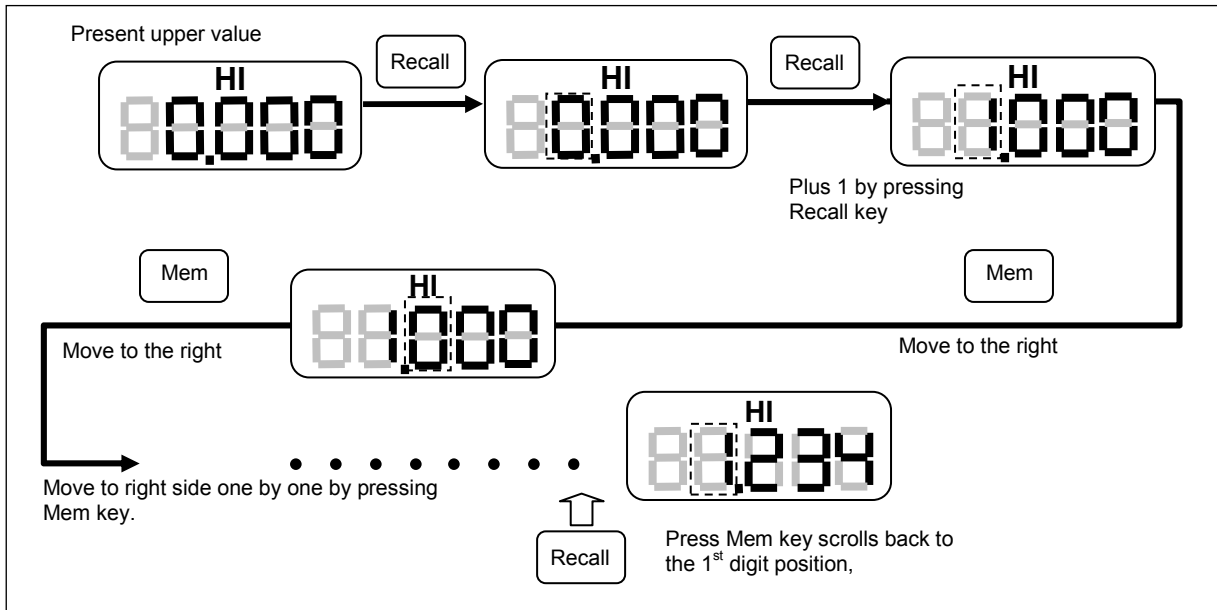

Zero/RST

Pressing Zero/RST, it moves to the next function setting.

Function Mode – Lower comparator value (Lo Limit)

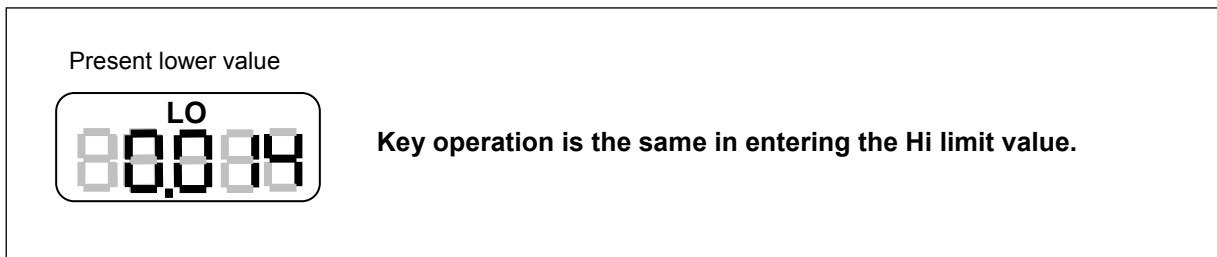

Zero/RST

Move to setting register/ standard display

Use the MODE key to change values of each function.
Use the Zero/RST key for moving to the next function

Operation

Pretest Checklist:

Determine the size of the sample to be tested. Adjust the 4 jig on the testing table accordingly. Center the sample and use the knob to secure the sample in place (clockwise to tighten the jig to the sample material).



It is important to make sure that all the jigs are flush to the moving brackets. Each one of these jigs has set pins which slides into place inside the grooved brackets.

Measuring Modes

Measuring Modes available on the TNP: OPEN, CLOSE, MEAN

Select the measuring mode required for testing. Please check the settings below on how to select the right mode for testing.

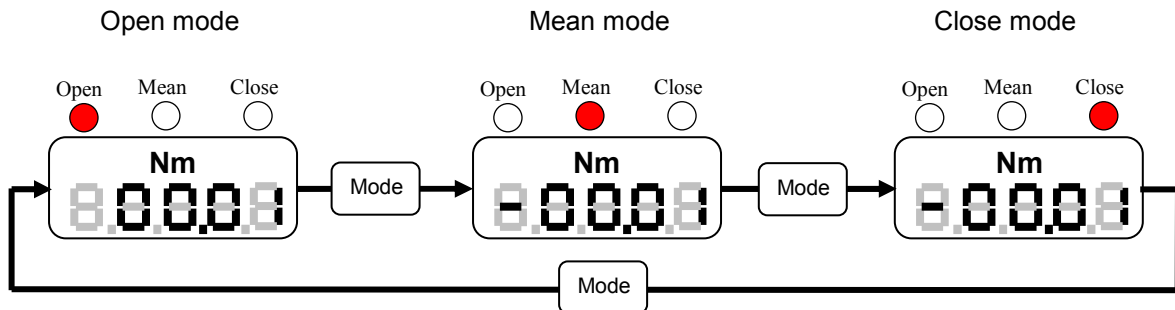

Pressing the Mode key toggles through the mode available from the TNP, LED indicators are provided to display current selected mode.

OPEN and CLOSE modes are PEAK Values captured by the TNP, these values are not real time values, and are retained on the display until one of the following occurs, the Zero/RST key is pressed or a higher peak value is detected (which in this case, replaces the current value detected).

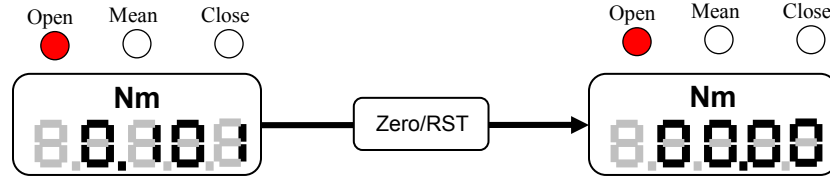

Resetting the Peak values to Zero

MEAN is real time value based on the average data captured in 1000 samples per second.

The maximum display update for all modes is 8 times/second.
 This update rate can be adjusted by changing F02 from function mode (See section - Values available 1, 2, 4, 8 times/second).

Comparator Function

This compares the measured value to the upper and lower limits entered under function mode for HI and LO limits.

If both HI and LO limits are set to "0000" this feature is not available (deactivated).

The following conditions are valid under comparator mode:

- HI>LO
- HI=LO (HI Red LED indicator will be lit on the Comparator LED indicators).

Utilizing this feature makes it an ideal tool for quality assurance checks.

Example: HI is set to 100 and LO is set to 50. Based from the conditions met the corresponding LED will light up (HI (Red LED), GO (Green LED), LO (Red LED)).

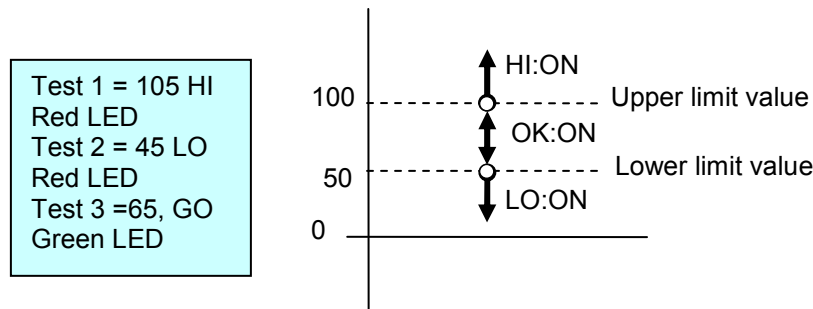

From the previous example any values greater than 100 will light up the HI red LED.

Any values lower than 50 will light up the LO red LED.

Values measured in between these values ($100 < X < 50$) will give a GO green LED indicator.

How to change the HI and LO values from the TNP torque meter?

- To set the HI and LO limits from the TNP torque meter access the function mode. (See Diagram How to Access the Function).
- Power off the torque meter
- Press and hold the Zero/RST key then power on the torque meter.
- Continue to hold on the Zero/RST key until the main display shows F01



- Press the Zero/RST key until the main display shows HI limit
- Using the Recall key we can increment the highlighted digit from 0-9.
- Press the Mem key to move from left to right or to the next digit.
- Entering values that are invalid the display will blink momentarily indicating wrong values entered to the HI and LO limits. (HI>LO, HI=LO). After entering the LO limit value and pressing the Zero/RST button the torque tester will go back to normal operation.

Zero adjustment / Tare the TNP

Taring or zeroing the value of the TNP initialize the torque meter to zero. This function is performed by pressing Zero/RST button on the front panel. In OPEN and CLOSE modes this zeros out the Peak values measured.



It is essential that the TNP be zeroed out before performing another test. This ensures that the TNP is properly initialized and no additional values are added to the measurement.

Saving Data in Memory

Data can be stored in the TNP meter by pressing the Mem key. This feature is only available in OPEN and CLOSE measuring modes.

NOTE: In MEAN or Average mode the Mem key has no function.

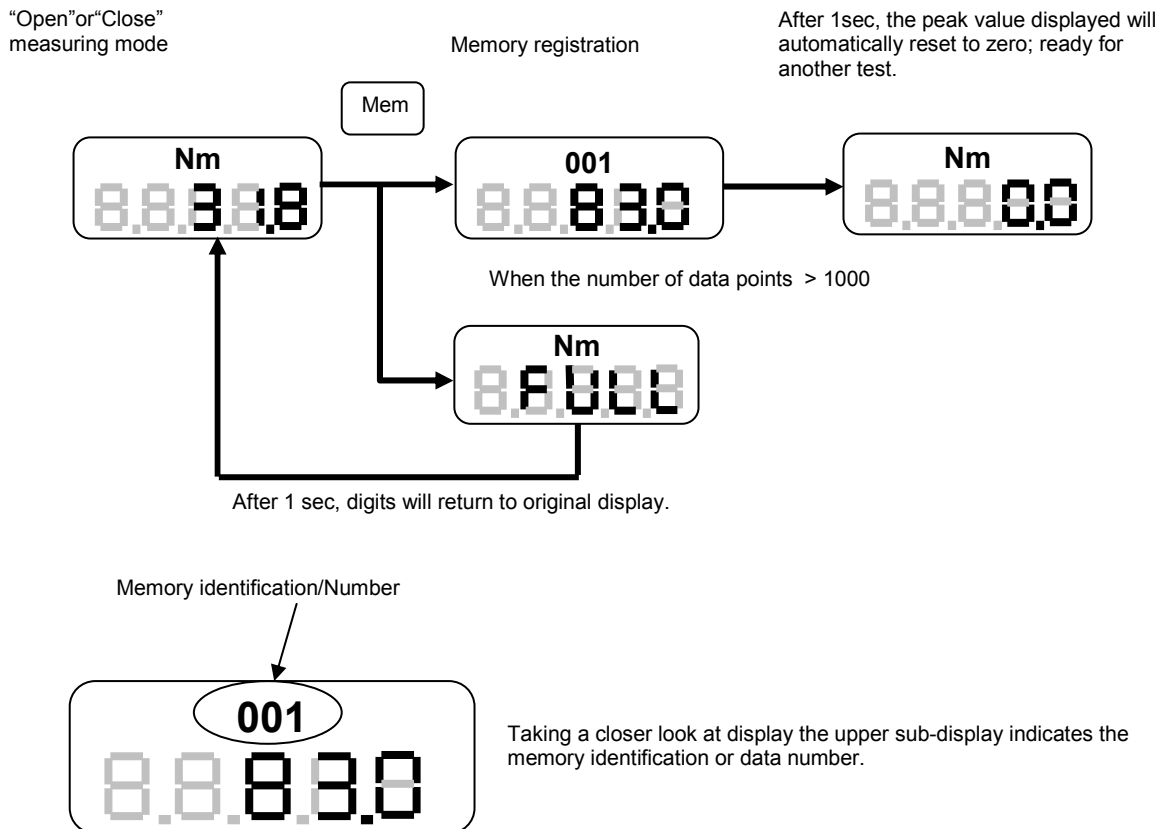

How to recall stored Memory

Select Open or Close Mode, press the Recall key and the display will indicate the number of data stored in memory.



Press Recall key second time to access the following information.

- AVERAGE Value
- MAX Value
- MIN Value
- Stored data (Data order of recall is based from the last data stored in memory)



Displays Max Values after pressing Recall

To access the stored measured value use the Recall key to scroll thru the values. (This will be after the MIN value is displayed). The display will flash two sets of numbers, the first number indicates the memory ID and the second number is the value stored on that memory ID.

NOTE: The order of values is from the last data stored to the first data stored. To review previous values shown, scroll through the values using the Recall key.



Picture above indicates the memory ID followed by the stored data. Pressing the mode button anytime exits out of the memory window. Below is a flowchart of how the recall function works.

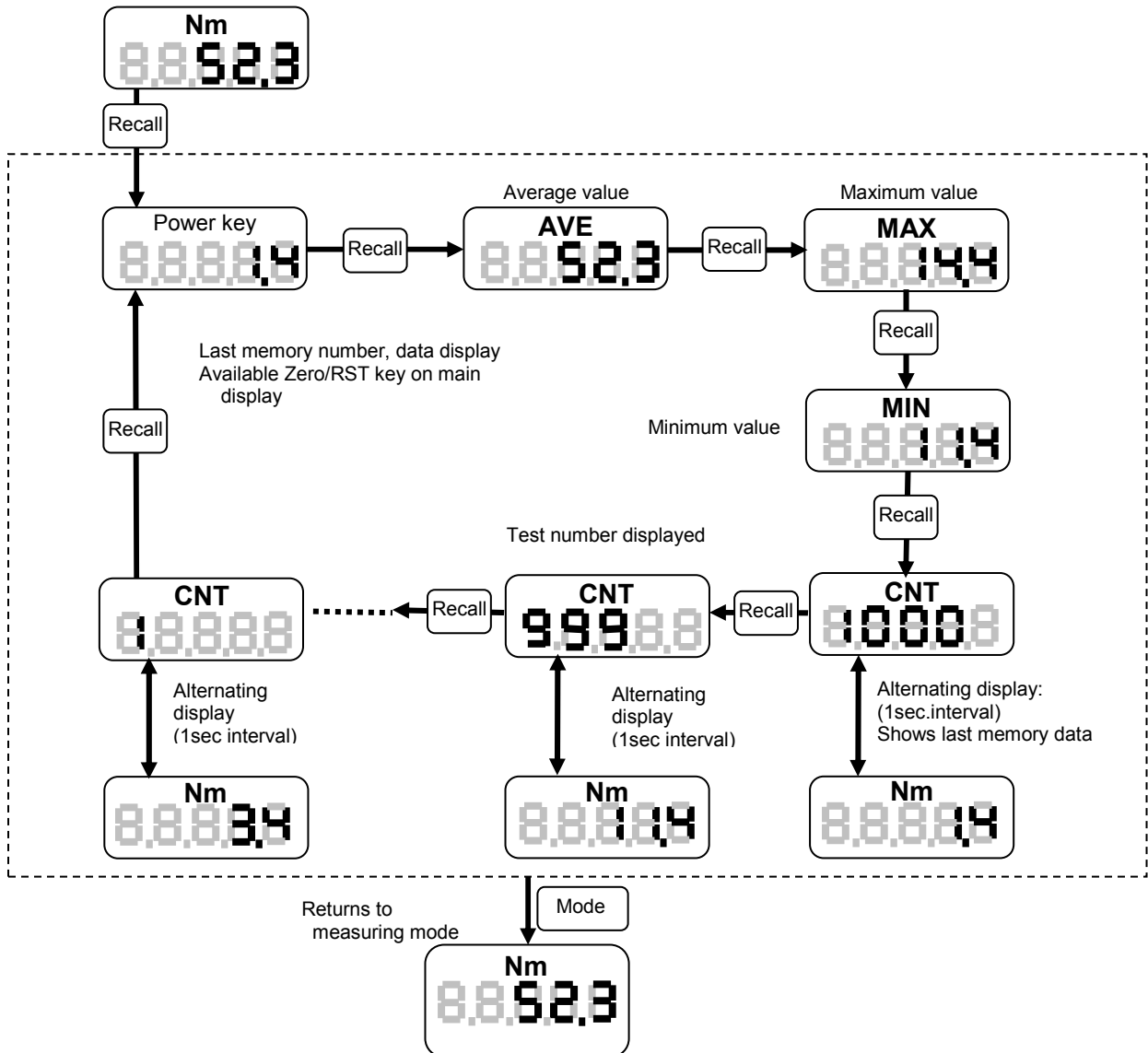

Clearing Stored Data

There are two types of memory clear available on the TNP torque meter.

- Single memory clear
- Clear all memory

Single Memory Clear

Single clear refers to erasing the stored data manually from the torque tester. The erase process starts from the most recent to the very first data stored.



Clearing data that is within the set cannot be accomplished by a single memory clear. The TNP does not allow the user to select the memory to be deleted. (jump out of sequence).

How does it work?

First select from Open or Close Modes (Mean or average mode data cannot be stored).

Press the Recall key to access memory, the first display you see will indicate the number of data stored in the torque tester and the last value saved.



Example from the picture above shows 3 data is saved (003) and the last value is 12.6. Pressing the Zero/RST button, the last data is eliminated (CLr will appear on the screen). Pressing the Zero/RST button again deletes the next data stored in the TNP torque meter.

Here is a flowchart of how the single clear works.

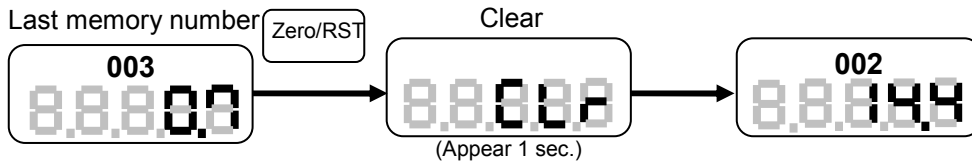

When there is one last data, the last data is cleared by pressing Zero/RST key. After that, “nonE” is displayed at main display for 2 seconds, then the display returns to measuring mode as shown below:

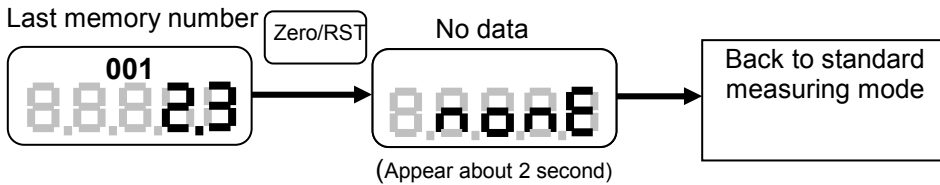

After all the data are erased pressing the Zero/RST button returns the display to normal measuring condition.

Clear all Memory

Clear all Memory or erasing all stored data in memory is possible by doing the following.

- Power off the TNP torque meter
- Press the **Mem** key and continue to hold this key while powering the torque tester. The TNP will initialize itself. You will see the model capacity displayed on the front panel then followed by the message “nonE”. This indicates that all data stored in memory have been erased or cleared.

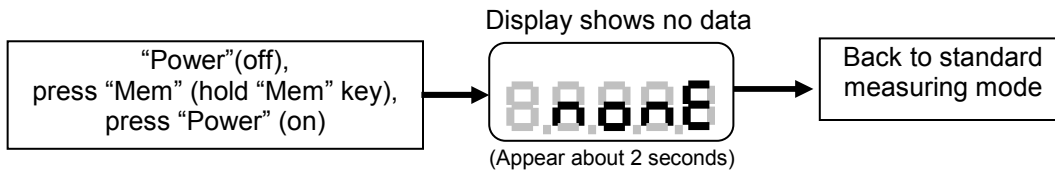

DIMENSIONS

